

<p>WORKING JOURNAL – REPORT ABOUT ACTIVITIES BEFORE AND AFTER THE MEETING</p> <hr/> <p>LEONARDO SCHOOL PARTNERSHIP</p>  <p><i>I. tehnička škola TESLA</i></p> <hr/> <p>2011-1-SI1-LEO04-02712 5</p>	<p>Romania from 27.05.2011. to 03.06.2012.</p> 	<p>NAME AND SURNAME OF STUDENT, class:</p> <p>Matej Kramarić</p> <p>3.D</p>
<p>ACTIVITIES THAT I DID AND PROCEEDED MY FOR WORK IN ROMANIA</p> <p>(Working with professors Nemeš, Vukšić, Tokmačić, Novaković, Antić)</p>		
	<p>DIRECT WORKING ACTIVITIES WEIL STAYING IN BRAILA</p>	<p>COOPERATION WITH STUDENTS FROM OTHER SCHOOLS, WHAT, HOW AND WHEN</p>
<p>27.05.2012.</p>	<ul style="list-style-type: none"> - first the flight from Zagreb to Frankfurt and then from Frankfurt to Bucharest - from Bucharest driving with Slovenian students in mini bus to Grand Hotel Orient in Braila - dinner with professors in restaurant 	<ul style="list-style-type: none"> - getting to know the Slovenian team weil driving in mini bus to hotel in Braila
<p>28. 05.2012.</p>	<ul style="list-style-type: none"> - after breakfast, we were going to the school in Braila where we had our presentation about our school, then starting on our project - we were divided in 3 separated groups, every group had to make the program in Siemens Logo, the electrical scheme in ePlan, the glossary and presentation about our work - the AVC teams from Germany and Slovenia were capturing all our work with video cameras 	<ul style="list-style-type: none"> - after the presentation we meet the Spanish team

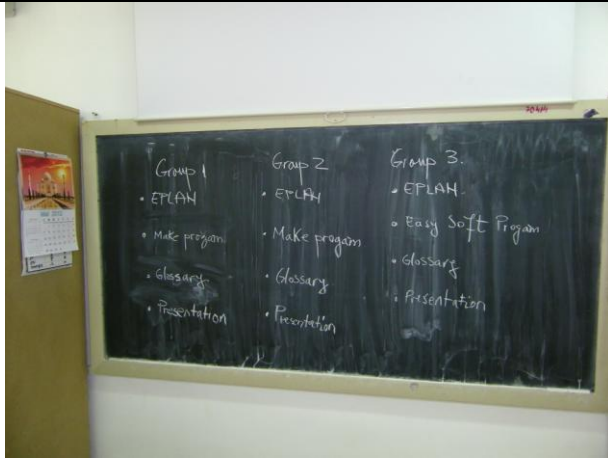

- I was in the first group with one German student, Spanish student and two Romanian students

- our task looked like this:



- the task was to make the first motor run and then if one of the two switches went out in some kind of emergency situation out the second motor had to start running

- after finishing our ePlan scheme and Siemens logo logic scheme our work was done for today

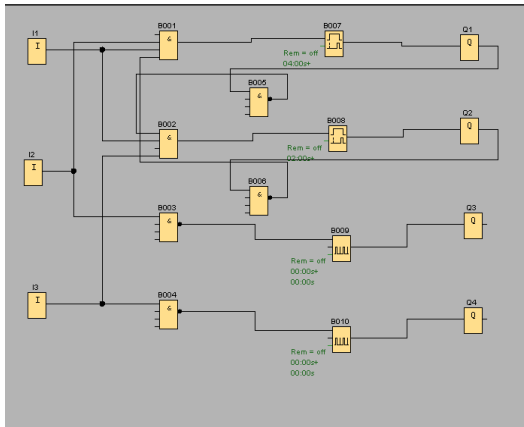
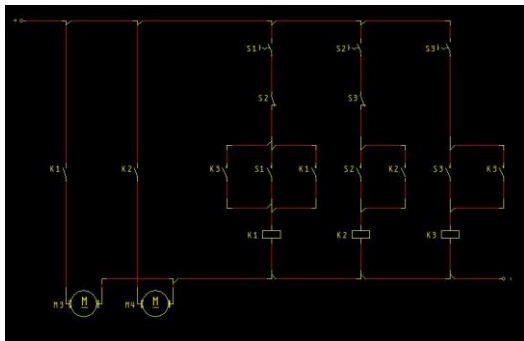

- in the school were we did our project we meet the other students from Belgia, Germany and Romania
 - I was in my gruop with Max from Germany, Johanna from Spain and two other Romanian students
 - Max and I did the logic scheme in Siemens Logo, the Romanians did the glossary and Max did the ePlan scheme

- after working on our task we had some time for sport activities in the sports gym in the school, we played soccer with the Slovenians, Belgians and Romanians

- in the night we all went out together for some fun time in the city of Braila

29. 05.2012.

- in the morning we all had breakfast together in the hotel, and after we finished eating we went to the school to continue our work on project
- we had to finish our presentation and words for glossary
- we visited a greek house and theater in Braila



- later we went for lunch all together and in the night we had some free time for fun activities and dinner

- working with my team on project (Max and Johanna)
- finishing the presentation all together, doing the glossary
- I did learn some Romanian language with one of the Romanian students (Andrei)
- going to the mall in Braila with Spanish students

30. 05.2012.

- departure to Sinaia in the morning after breakfast with bus
- arriving at hotel in Sinaia, leaving our baggage in hotel rooms and then going for lunch at hotel
- driving with the bus to 1400 m above sea level and taking the cable car all the way down



- walking to the hotel and then going for dinner with other students and teachers

- taking the ride with Spanish students in cable car and then walking to the hotel
- we all stayed for a bit in the hotel to get some rest
- in the night we went for dinner together with Spanish students

31. 05.2012.

- having breakfast in hotel and then going to visit Draculas Castle



- after that we went to see the city of Brasov, in Brasov we went to see the Black church



- in the night we all came back to the hotel and then went for dinner

- visiting Draculas castle with all students and teachers, talking with other students
- taking a walk in the city of Brasov with Spanish students
- having lunch all together in restaurant
- in the night going with Spanish students for dinner in Sinaia

01.06.2012.

- after breakfast it was time for presentations of our work in school in Braila
- every group had to make the presentation, including the AVC team and we had to fill in an evaluation
- then we went all together to visit the Peles castle



- lunch at Sinaia and walking after to the hotel
- having dinner with all students and teachers together in Irish pub

- preparing for presentation with my group
- talking on german and spanish
- walking to the Peles castle in Sinaia with Spanish and Belgian students
- going for dinner together with Spanish and Belgian students
- talking and hanging out in the hotel

02.06.2012.

- after breakfast (which I missed) we all went to the train station in Sinaia to take the train to Bucharest
- when we arrived to Bucharest we had to say goodbye to the German, Belgian and Slovenian team because they were leaving home today
- only we and the Spanish team stayed in Bucharest



- after a coffee break we took a taxi to the hotel Relax Comfort in Bucharest
- we all went for lunch in the city center



- we saw the Bucharest parliament which is the biggest parliament in Europe and the second largest in the world



- after lunch we went back to the hotel to take some rest and in the night we went together for dinner

- waiting for the train in Sinaia all together
- farewell with Belgian, Slovenian and German students
- walking around the city of Bucharest with Spanish team, having lunch and talking
- having fun and resting in the hotel
- going out for dinner at night with Spanish students

<p>03.06.2012.</p>	<ul style="list-style-type: none"> - early in the morning I sayed goodbye to the Spanish team - now it was only us four Croatians having breakfast at the hotel and then going to the airport for plane to Vienna - first we took the metro and then a taxi to see the Arch of triumph in Bucharest  <ul style="list-style-type: none"> - the taxi drove us to the train station, we took the train to the airport and a bus finnaly brought us to the airport - first we took the flight to Vienna and from Vienna after a three our wait we took the plane to Zagreb 	<ul style="list-style-type: none"> - farewell with Spanish team
<p>EVALUACIJA SUSRETA, KOMENTARI, NAPOMENE,</p>	<p>Before coming to Romania we were very uncertain about our knowledge in English language and how would we adapt to this new environment in a country such as Romania.</p> <p>But after meeting everybody we knew everything would go smoothly and well because the other students were no better then us, either in talking English or knowledge.</p> <p>We finished our project with no problems at all and we all had a very good time.</p> <p>Just being there and experience something like this project in Romania was really a one in a life time experience and I really hope we could do this soon again and more often.</p> <p>I'm thankful for all that my teachers had to do to make this all happen and prepare us for going there and to everybody who was there working on this project.</p> <p>Thank you</p>	